



30mm Multi-hole



CONFIGURATION
4 cover screws, lift off cover



F Construction

Material	SolarGuard® – Hot compression molded fiberglass reinforced polyester (thermoset)
Gasket	Poured polyurethane seamless gasket provides watertight, dust-tight environmental seal
Cover screws	Recessed captive stainless steel screws
Stainless Steel Hardware	300 Series stainless used on all external hardware
Enclosure Mounting	Integral mounting flange for ease of mounting
Cover Retention Chain	Stainless steel beaded chain for securing cover after lift off
Panel Mounting	Back panel utilizes threaded brass inserts accepting 10-32 screws. Cover accepting 10-24 screws.
Soft Edge Design	Rounded edges, minimal protrusions or exposed pocket areas for assembly of dust and debris
Color	Available standard glacier grey (PMS 428C)

F Modifications

Custom Colors	pg. 21-22
Custom Painting	pg. 21-22
Silk Screening	pg. 21-22
Custom Cutouts/Holes	pg. 21-22

F Industry Standards

NEMA 250, UL Listed UL50, UL50e, UL508A	File E64358 Type 1, 3R, 4X, 6P, 12
CSA Std C22.2	File LR069014 Type 1, 3R, 4X, 6P, 12
IEC 60529	UL File E362920 IP 66, IP67, IP68
Plenum Space (UL2043) Compliant	Yes
Temperature Range	(-76°F to +274°F) (-60°C to +134°C)
Flammability Rating	UL94-5V
Impact Rating	IK10
Self Extinguishing	Non-flame propagating
Chemical Resistance	Full chemical resistance charts listed in appendix
NFPA No. 101 Flame Spread	Class A (1)
Outdoor Exposure UL746C	(F1) Rated

F Accessories

Mounting Feet	pg. 192
----------------------	---------

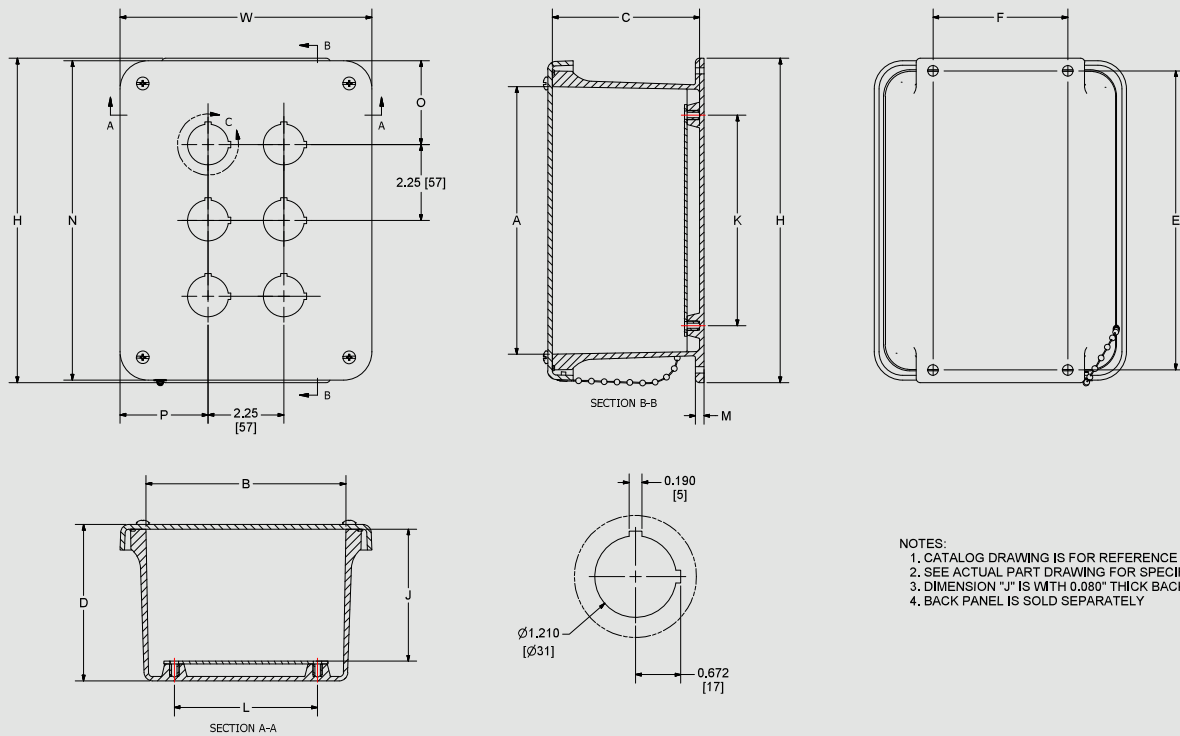

- NOTES:
 1. CATALOG DRAWING IS FOR REFERENCE ONLY
 2. SEE ACTUAL PART DRAWING FOR SPECIFIC DESIGN
 3. DIMENSION "J" IS WITH 0.080" THICK BACK PANEL INSTALLED
 4. BACK PANEL IS SOLD SEPARATELY

SCREW SIZES & TORQUE VALUES

PRODUCT SIZES	BACK PANEL SCREW SIZE	BACK PANEL RECOMMENDED TORQUE	COVER SCREW SIZE	COVER SCREW RECOMMENDED TORQUE	RECOMMENDED MOUNTING FLANGE TORQUE
All Sizes	#10-32 x 3/8	16 - 20 in-lbs	#10-24 x 3/4	20 - 24 in-lbs	45 in-lbs max

Pushbutton Series – 30mm Multi-hole

CATALOG NUMBER	HOLE CONFIG.	OVERALL H X W X D	INSIDE A X B X C	MOUNTING E X F	J	K	L	M	N	O	P	HOLE DIA.	SHIP WEIGHT	PANEL NUMBER
F4PBW	2 x 2	7.50 x 7.50 x 4.75 (191 x 191 x 121)	5.72 x 5.72 x 4.45 (145 x 145 x 113)	6.75 x 4.00 (171 x 101)	4.00 (101)	4.25 (108)	4.25 (108)	0.25 (6)	7.52 (191)	2.64 (67)	2.64 (67)	0.31 (8)	2.7 lbs.	BP66*
F6PBW	3 x 2	9.62 x 7.50 x 4.74 (244 x 191 x 121)	7.73 x 5.74 x 4.45 (196 x 146 x 113)	8.88 x 4.00 (225 x 101)	4.00 (101)	6.25 (159)	4.25 (108)	0.25 (6)	9.5 (242)	2.64 (67)	2.51 (64)	0.31 (8)	3.5 lbs.	BP86*
F9PBW	3 x 3	11.62 x 9.41 x 4.25 (295 x 239 x 108)	9.73 x 7.73 x 3.98 (247 x 196 x 101)	10.75 x 6.00 (273 x 152)	3.50 (89)	8.25 (209)	6.25 (159)	0.25 (6)	11.35 (288)	3.43 (87)	2.45 (62)	0.31 (8)	5.0 lbs.	BP108*

All measures are in inches, items in parentheses are in millimeters.
 Note: F6PBW shown for reference



*Panel sold separately