



Opaque Cover

CONFIGURATION
Hinged, 2 cover screws



HW Construction

Material	SolarGuard® – Hot compression molded fiberglass reinforced polyester (thermoset)
Gasket	Poured polyurethane seamless gasket provides watertight, dust-tight environmental seal.
Pan Head Screws	Minimized protruding surfaces
Stainless Steel Hardware	300 Series stainless used on all external hardware.
Molded in Mounting Flange	Molded in flange for ease of mounting.
Mounting Bosses	Panel mounting capability for fixed rear panel.
Metal Inserts	Back panel utilizes threaded brass inserts accepting 10-32 screws; cover accepting 10-24 screws.
Soft Edge Design	Rounded edges, minimal protrusions or exposed pocket areas for assembly of dust and debris.
Color	Available Standard in Glacier Grey (PMS 428C) or White*.

HW Modifications

Custom Colors	pg. 21-22
Silk Screening	pg. 21-22
EMI/RFI Shielding	pg. 21-22
Custom Window	pg. 21-22
Custom Cutouts/Holes	pg. 21-22

HW Industry Standards

NEMA 250, UL Listed UL50, UL50e, UL508A	File E64358 Type 1, 3R, 4X, 6P*, 12
CSA Std C22.2	File LR069014; Type 1, 3R, 4X, 6P*, 12
IEC 60529	File E362920 IP66; IP 6X for 3PT
UL1741	File E333478; W, HW, HPL, FHW
Plenum Space (UL2043) Compliant	Yes
Temperature Range	(-76°F to +274°F) (-60°C to +134°C)
Flammability Rating	UL94-5V
Impact Rating	IK10
Self Extinguishing	Non-halogenated, non-flame propagating
Chemical Resistance	Full chemical resistance charts listed in appendix
NFPA No. 101 Flame Spread	Class A (1)
Outdoor Exposure UL746C	(f1) Rated

HW Accessories

PANELS	Aluminum	BP_AL	pg. 174-175
	Fiberglass	BP_FG	pg. 174-175
	Stainless Steel	BP_SS	pg. 174-175
	Carbon Steel	BP_CS	pg. 174-175
ACCESSORIES	Dead Front Panels		pg. 180-181
	Drain & Breather Vents		pg. 185
	Hole Plugs		pg. 187
	Assorted Hubs and Cord Grips		pg. 188-189
	All Other Accessories		pg. 184-194

* Consult Factory on available sizes.

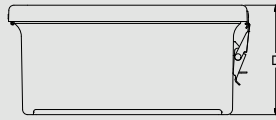
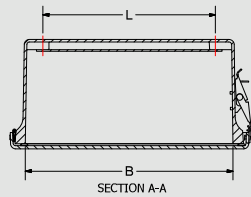

- NOTES:
1. CATALOG DRAWING IS FOR REFERENCE ONLY
 2. SEE ACTUAL PART DRAWING FOR SPECIFIC DESIGN
 3. "J" DIMENSION IS WITH 0.080" THICK BACK PANEL INSTALLED
 4. BACK PANEL IS SOLD SEPARATELY

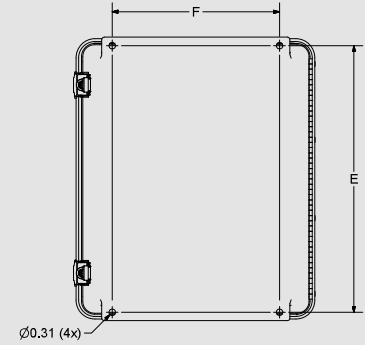
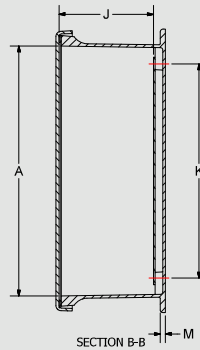
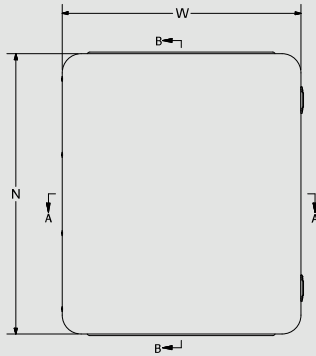
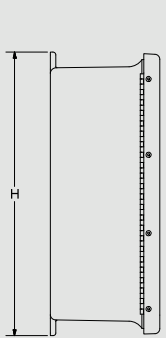

SCREW SIZES & TORQUE VALUES

PRODUCT SIZES	BACK PANEL SCREW SIZE	BACK PANEL RECOMMENDED TORQUE	COVER SCREW SIZE	COVER SCREW RECOMMENDED TORQUE	RECOMMENDED MOUNTING FLANGE TORQUE
J604 up to J2016	#10-32 x 3/8	16 - 20 in-lbs	#10-24 x 5/8	20 - 24 in-lbs	45 in-lbs max
J2020 up to J2424	1/4-20 x 1/2	20 - 24 in-lbs	N/A	N/A	80 in-lbs max

J Series – Opaque Cover

CATALOG NUMBER	OVERALL H X W X D	INSIDE A X B X C	MOUNTING E X F	J	K	L	M	N	HOLE DIAMETER	SHIP WEIGHT	PANEL NUMBER
J604HPL*** J604HW*** J604W J604HLL	7.47 x 5.45 x 4.70 (190 x 138 x 119)	5.84 x 3.85 x 4.45 (148 x 98 x 113)	6.75 x 2.00 (171 x 51)	3.97 (101)	4.25 (108)	2.25 (57)	0.25 (6)	7.39 (188)	0.31 (8)	2.40 lbs.	BP64**
J606HPL*** J606HW*** J606W J606HLL	7.50 x 7.53 x 4.82 (191 x 191 x 122)	5.72 x 5.72 x 4.45 (145 x 145 x 113)	6.75 x 4.00 (171 x 101)	3.97 (101)	4.25 (108)	4.25 (108)	0.25 (6)	7.53 (191)	0.31 (8)	2.80 lbs.	BP66**
J806HPL*** J806HW*** J806W J806HLL J806FHW	9.63 x 7.52 x 4.70 (245 x 191 x 119)	7.73 x 5.74 x 4.45 (196 x 146 x 113)	8.88 x 4.00 (225 x 101)	3.92 (100)	6.25 (159)	4.25 (108)	0.25 (6)	9.5 (242)	0.31 (8)	3.50 lbs.	BP86**
J808HPL*** J808HW*** J808W J808HLL J808FHW	9.56 x 9.38 x 4.87 (243 x 238 x 124)	7.73 x 7.73 x 4.62 (196 x 196 x 117)	8.75 x 6.00 (222 x 152)	3.98 (101)	6.25 (159)	6.25 (159)	0.25 (6)	9.38 (238)	0.31 (8)	3.80 lbs.	BP88**

All measures are in inches, items in parentheses are in millimeters.



*Crowned cover - center of cover raised 3/4"



**Panel sold separately



***Available in white by placing WH prior to part number. Ex: WH-J604HW



J Series – Opaque Cover

CATALOG NUMBER	OVERALL H X W X D	INSIDE A X B X C	MOUNTING EX F	J	K	L	M	N	HOLE DIA.	SHIP WEIGHT	PANEL NUMBER
J1008HPL*** J1008HW*** J1008W J1008HLL J1008FHW	11.63 x 9.41 x 4.22 (295 x 239 x 107)	9.73 x 7.73 x 3.98 (247 x 196 x 101)	10.75 x 6.00 (273 x 152)	3.44 (87)	8.25 (210)	6.25 (159)	0.25 (6)	11.35 (288)	0.31 (8)	4.60 lbs.	BP108**
J1008HWA* J1008WA* J1008HALL*	11.63 x 9.37 x 5.05 (295 x 238 x 129)	9.73 x 7.73 x 4.83 (247 x 196 x 123)	10.75 x 6.00 (273 x 152)	4.38 (111)	8.25 (210)	6.25 (159)	0.25 (6)	11.38 (289)	0.31 (8)	4.70 lbs.	BP108**
J100806HPL*** J100806HW*** J100806W J100806HLL J100806FHW	11.97 x 9.42 x 6.61 (304 x 239 x 165)	9.74 x 7.74 x 6.25 (248 x 197 x 159)	10.94 - 10.75 x 6.00 (278 - 273 x 152)	5.67 (141)	8.25 (210)	6.25 (159)	0.25 (6)	11.42 (290)	0.31 (8)	5.20 lbs.	BP108**
J1210HPL*** J1210HW*** J1210W J1210HLL J1210FHW	13.56 x 11.43 x 5.22 (344 x 291 x 133)	11.79 x 9.80 x 4.94 (299 x 249 x 125)	12.75 x 8.00 (324 x 203)	4.50 (114)	10.25 (260)	8.25 (210)	0.25 (6)	13.41 (341)	0.31 (8)	6.60 lbs.	BP1210**
J1212HPL*** J1212HW*** J1212W J1212HLL J1212FHW	13.56 x 13.38 x 6.34 (344 x 340 x 161)	11.70 x 11.70 x 6.10 (297 x 297 x 155)	12.75 x 10.00 (324 x 254)	5.51 (140)	10.25 (260)	10.25 (260)	0.25 (6)	13.38 (340)	0.31 (8)	8.40 lbs.	BP1212**
J1407HPL*** J1407HW*** J1407W J1407HLL J1407FHW	15.87 x 8.75 x 6.81 (403 x 222 x 173)	14.00 x 7.00 x 6.56 (356 x 178 x 167)	15.00 x 5.00 (381 x 127)	6.11 (155)	12.25 (311)	5.25 (133)	0.25 (6)	15.75 (400)	0.31 (8)	6.10 lbs.	BP1407**
J1412HPL*** J1412HW*** J1412W J1412HLL J1412FHW	15.50 x 13.48 x 6.20 (394 x 342 x 158)	13.52 x 11.52 x 5.94 (343 x 293 x 151)	14.63 x 10.00 (372 x 254)	5.36 (137)	12.25 (311)	10.25 (260)	0.25 (6)	15.48 (393)	0.31 (8)	9.90 lbs.	BP1412**
J1614HPL*** J1614HW*** J1614W J1614HLL J1614FHW	17.53 x 15.46 x 6.21 (445 x 393 x 157)	15.60 x 13.56 x 5.94 (396 x 344 x 151)	16.75 x 12.00 (425 x 305)	5.35 (136)	14.25 (362)	12.25 (311)	0.25 (6)	17.46 (444)	0.31 (8)	12.20 lbs.	BP1614**
J1816HPL*** J1816HW*** J1816W J1816HLL J1816FHW	19.63 x 17.63 x 8.81 (499 x 447 x 224)	17.69 x 15.69 x 8.45 (449 x 399 x 215)	18.88 x 12.00 (479 x 305)	7.98 (203)	16.25 (413)	14.25 (362)	0.25 (6)	19.61 (498)	0.31 (8)	20.00 lbs.	BP1816**
J2016HPL*** J2016HW*** J2016W J2016HLL J2016FHW	22.00 x 17.68 x 8.81 (559 x 449 x 224)	19.72 x 15.72 x 8.45 (501 x 399 x 215)	21.25 x 10.00 (540 x 254)	7.98 (203)	18.25 (464)	14.25 (362)	0.25 (6)	21.68 (551)	0.31 (8)	22.50 lbs.	BPJ2016**
J2020HPL J20203PT	23.50 x 22.12 x 11.70 (597 x 562 x 297)	19.88 x 19.88 x 11.33 (505 x 505 x 288)	21.88 x 18.30 (556 x 465)	10.49 (266)	15.25 (387)	15.25 (387)	0.50 (13)	22.1 (561)	0.44 x 0.38 (11 x 10)	30 lbs.	BPJ2020**
J2420HPL J24203PT	27.50 x 22.12 x 11.70 (699 x 562 x 297)	23.88 x 19.88 x 11.33 (607 x 505 x 288)	25.88 x 18.30 (657 x 465)	10.49 (266)	19.25 (489)	15.25 (387)	0.50 (13)	26.1 (663)	0.44 x 0.38 (11 x 10)	36 lbs.	BPJ2420**
J2424HPL J24243PT	27.50 x 26.12 x 11.70 (699 x 663 x 297)	23.88 x 23.88 x 11.33 (607 x 607 x 288)	25.88 x 22.00 (657 x 559)	10.49 (266)	19.25 (489)	19.25 (489)	0.50 (13)	26.1 (663)	0.44 x 0.38 (11 x 10)	42 lbs.	BPJ2424**

All measures are in inches, items in parentheses are in millimeters.



*Crowned cover – center of cover raised 3/4"



**Panel sold separately



***Available in white by placing WH prior to part number. Ex: WH-J604HW