



Raised Opaque Cover



CONFIGURATION
Hinged, 2 cover screws

HW Construction

Material	SolarGuard® – Hot compression molded fiberglass reinforced polyester (thermoset)
Gasket	Poured polyurethane seamless gasket provides watertight, dust-tight environmental seal
Pan Head Screws	Minimizes protruding surfaces
Stainless Steel Hardware	300 Series stainless used on all external hardware
Molded in Mounting Flange	Integral flange molded in place for ease of mounting
Mounting Bosses	Panel mounting capability for fixed rear panel
Metal Inserts	Back panel utilizes threaded brass inserts accepting 10-32 screws. Cover accepting 10-24 screws.
Soft Edge Design	Rounded edges, minimal protrusions or exposed pocket areas for assembly of dust and debris
Raised Cover	Extended depth in cover
Color	Available standard glacier grey (PMS 428C)

HW Modifications

Custom Colors	pg. 21-22
Silk Screening	pg. 21-22
EMI/RFI Shielding	pg. 21-22
Custom Window	pg. 21-22
Custom Cutouts/Holes	pg. 21-22

HW Industry Standards

NEMA 250, UL Listed UL50, UL50e, UL508A	File E64358 Type 1, 3R, 4X, 6P, 12
CSA Std C22.2	File LR069014; Type 1, 3R, 4X, 6P, 12
IEC 60529	File E362920 IP66
UL1741	File E333478; W, HW, HPL, FHW
Plenum Space (UL2043) Compliant	Yes
Temperature Range	(-76°F to +274°F) (-60°C to +134°C)
Flammability Rating	UL94-5V
Self Extinguishing	Non-halogenated, Non-flame propagating
Chemical Resistance	Full chemical resistance charts listed in appendix
NFPA No. 101 Flame Spread	Class A (1)
Outdoor Exposure UL746C	(f1) Rated

HW Accessories

PANELS	Aluminum	BP_AL	pg. 174-175
	Fiberglass	BP_FG	pg. 174-175
	Stainless Steel	BP_SS	pg. 174-175
	Carbon Steel	BP_CS	pg. 174-175
ACCESSORIES	Dead Front Panels		pg. 180-181
	Drain & Breather Vents		pg. 185
	Hole Plugs		pg. 187
	Assorted Hubs and Cord Grips		pg. 188-189
	All Other Accessories		pg. 184-194

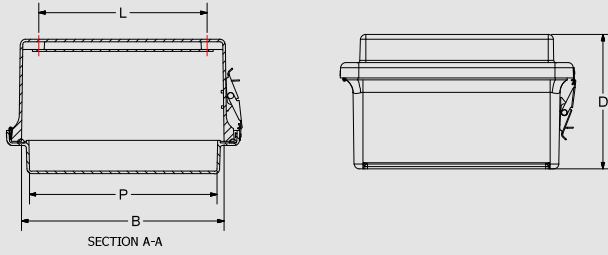

- NOTES:
 1. CATALOG DRAWING IS FOR REFERENCE ONLY
 2. SEE ACTUAL PART DRAWING FOR SPECIFIC DESIGN
 3. "J" DIMENSION IS WITH 0.080" THICK BACK PANEL INSTALLED
 4. BACK PANEL IS SOLD SEPARATELY

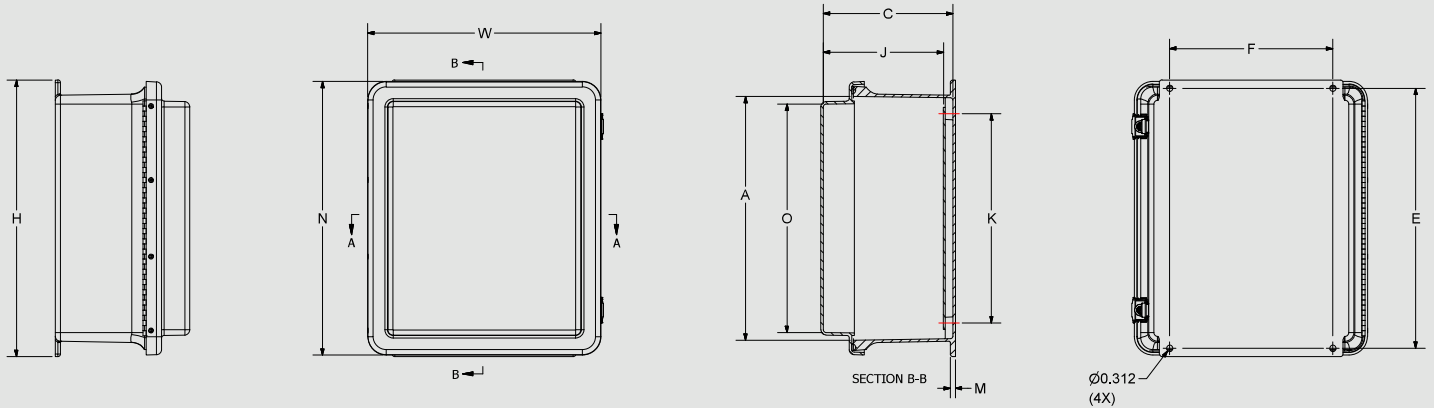

SCREW SIZES & TORQUE VALUES

PRODUCT SIZES	BACK PANEL SCREW SIZE	BACK PANEL RECOMMENDED TORQUE	COVER SCREW SIZE	COVER SCREW RECOMMENDED TORQUE	RECOMMENDED MOUNTING FLANGE TORQUE
RJ604 up to RJ2016	#10-32 x 3/8	16 - 20 in-lbs	#10-24 x 5/8	20 - 24 in-lbs	45 in-lbs max

RJ Series – Raised Opaque Cover

CATALOG NUMBER	OVERALL H X W X D	INSIDE A X B X C	MOUNTING E X F	J	K	L	M	N	O	P	HOLE DIA.	SHIP WEIGHT	PANEL NUMBER
RJ604HPL RJ604HW RJ604W RJ604HLL	7.47 x 5.47 x 6.21 (190 x 139 x 158)	5.84 x 3.85 x 5.95 (148 x 98 x 151)	6.75 x 2.00 (171 x 51)	5.51 (140)	4.25 (108)	2.25 (57)	0.25 (6)	7.45 (189)	5.31 (135)	3.34 (85)	0.31 (8)	2.60 lbs.	BP64*
RJ606HPL RJ606HW RJ606W RJ606HLL	7.50 x 7.53 x 6.32 (191 x 191 x 161)	5.72 x 5.72 x 5.97 (145 x 145 x 152)	6.75 x 4.00 (171 x 101)	5.49 (139)	4.25 (108)	4.25 (108)	0.25 (6)	7.53 (191)	5.34 (136)	5.31 (135)	0.31 (8)	3.10 lbs.	BP66*
RJ806HPL RJ806HW RJ806W RJ806HLL	9.63 x 7.52 x 6.20 (245 x 191 x 158)	7.73 x 5.74 x 5.95 (196 x 146 x 151)	8.88 x 4.00 (225 x 101)	5.49 (139)	6.25 (159)	4.25 (108)	0.25 (6)	9.36 (238)	7.25 (185)	5.28 (134)	0.31 (8)	3.70 lbs.	BP86*
RJ808HPL RJ808HW RJ808W	9.56 x 9.38 x 6.25 (243 x 238 x 159)	7.73 x 7.73 x 6.00 (196 x 196 x 152)	8.75 x 6.00 (222 x 152)	5.42 (138)	6.25 (159)	6.25 (159)	0.25 (6)	9.38 (238)	7.17 (182)	7.17 (182)	0.31 (8)	4.20 lbs.	BP88*

All measures are in inches, items in parentheses are in millimeters.



*Panel sold separately



RJ Series – Raised Opaque Cover

CATALOG NUMBER	OVERALL H X W X D	INSIDE A X B X C	MOUNTING E X F	J	K	L	M	N	O	P	HOLE DIA.	SHIP WEIGHT	PANEL NUMBER
RJ1008HPL RJ1008HW RJ1008W RJ1008HLL	11.63 x 9.37 x 6.58 (295 x 238 x 167)	9.73 x 7.73 x 6.33 (247 x 196 x 161)	10.75 x 6.00 (273 x 152)	5.87 (149)	8.25 (209)	6.25 (159)	0.25 (6)	11.38 (289)	9.3 (236)	7.38 (188)	0.31 (8)	5.20 lbs.	BP108*
RJ1210HPL RJ1210HW RJ1210W RJ1210HLL	13.56 x 11.43 x 6.58 (344 x 291 x 167)	11.79 x 9.80 x 6.32 (299 x 249 x 161)	12.75 x 8.00 (324 x 203)	5.87 (149)	10.25 (260)	8.25 (210)	0.25 (6)	13.41 (341)	11.2 (284)	9.23 (234)	0.31 (8)	6.70 lbs.	BP1210*
RJ1212HPL RJ1212HW RJ1212W RJ1212HLL	13.56 x 13.38 x 7.72 (344 x 340 x 196)	11.70 x 11.70 x 7.47 (297 x 297 x 190)	12.75 x 10.00 (324 x 254)	6.89 (175)	10.25 (260)	10.25 (260)	0.25 (6)	13.38 (340)	11.17 (284)	11.17 (284)	0.31 (8)	8.90 lbs.	BP1212*
RJ1412HPL RJ1412HW RJ1412W RJ1412HLL	15.50 x 13.38 x 7.69 (394 x 340 x 195)	13.52 x 11.52 x 7.45 (343 x 293 x 189)	14.63 x 10.00 (372 x 254)	6.86 (174)	12.25 (311)	10.25 (260)	0.25 (6)	15.42 (392)	13.2 (335)	11.16 (284)	0.31 (8)	10.20 lbs.	BP1412*
RJ1614HPL RJ1614HW RJ1614W RJ1614HLL	17.53 x 15.43 x 7.68 (445 x 392 x 195)	15.60 x 13.56 x 7.45 (396 x 344 x 189)	16.75 x 12.00 (425 x 305)	6.85 (174)	14.25 (362)	12.25 (311)	0.25 (6)	17.43 (443)	15.2 (386)	13.24 (336)	0.31 (8)	12.30 lbs.	BP1614*
RJ1816HPL RJ1816HW RJ1816W RJ1816HLL	19.63 x 17.63 x 10.63 (499 x 444 x 270)	17.69 x 15.69 x 10.31 (449 x 399 x 262)	18.88 x 12.00 (479 x 305)	9.86 (250)	16.25 (413)	14.25 (362)	0.25 (6)	19.49 (495)	17.25 (438)	15.25 (387)	0.31 (8)	19.50 lbs.	BP1816*
RJ2016HPL RJ2016HW RJ2016W RJ2016HLL	22.00 x 17.56 x 10.63 (559 x 446 x 270)	19.72 x 15.72 x 10.33 (501 x 399 x 262)	21.25 x 10.00 (540 x 254)	9.86 (250)	18.25 (464)	14.25 (362)	0.25 (6)	21.56 (548)	19.31 (490)	15.39 (391)	0.31 (8)	21.40 lbs.	BPJ2016*

All measures are in inches, items in parentheses are in millimeters.



*Panel sold separately